

## Product Change Notice (PCN)

Date: 6/16/2023

PCN Number: **PCN-0454746R-01**

To Our Customers:

We appreciate your use of our products. Our commitment in maintaining and improving processes is demonstrated by plans to enhance our product quality, reliability, and manufacturability. The purpose of this notice is to inform you of a product change.

Product(s) Affected: SJ2-25102B-SMT-TR, SJ2-25103A-SMT-TR

Reason(s) for Change: *Manufacturing process improvements*

Description of Change: *Mechanical, material, soldering, and packaging changes as shown below:*

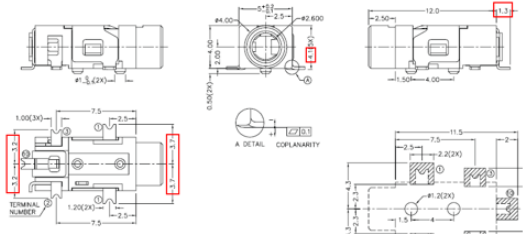
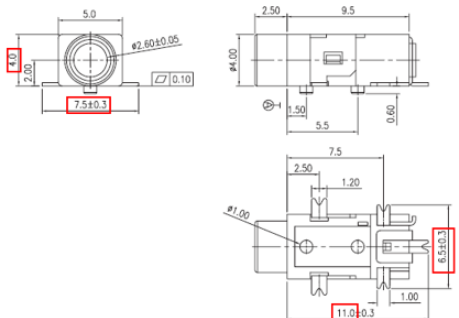
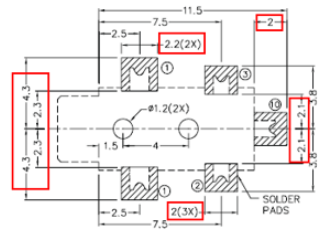
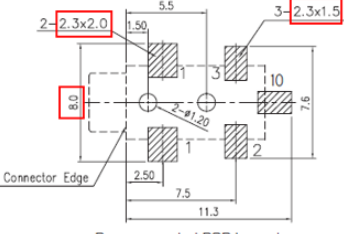
PREVIOUS CUI DEVICES DETAIL / IMAGE	NEW CUI DEVICES DETAIL / IMAGE																																				
																																					
 <p style="text-align: center;">Recommended PCB Layout Top View</p>	 <p style="text-align: center;">Recommended PCB Layout Top View</p>																																				
<table border="1" style="width: 100%; border-collapse: collapse;"> <thead> <tr> <th></th> <th>MATERIAL</th> <th>PLATING</th> </tr> </thead> <tbody> <tr> <td>terminal 1</td> <td>copper alloy</td> <td>silver</td> </tr> <tr> <td>terminal 2</td> <td>copper alloy</td> <td>silver</td> </tr> <tr> <td>terminal 3</td> <td>copper alloy</td> <td>silver</td> </tr> <tr> <td>terminal 10</td> <td>copper alloy</td> <td>silver</td> </tr> <tr> <td>plastic</td> <td>PA10T</td> <td></td> </tr> </tbody> </table>		MATERIAL	PLATING	terminal 1	copper alloy	silver	terminal 2	copper alloy	silver	terminal 3	copper alloy	silver	terminal 10	copper alloy	silver	plastic	PA10T		<table border="1" style="width: 100%; border-collapse: collapse;"> <thead> <tr> <th>DESCRIPTION</th> <th>MATERIAL</th> <th>PLATING/COLOR</th> </tr> </thead> <tbody> <tr> <td>terminal 1</td> <td>C5210 t=0.25</td> <td>gold flash over nickel</td> </tr> <tr> <td>terminal 2</td> <td>C5210 t=0.25</td> <td>gold flash over nickel</td> </tr> <tr> <td>terminal 3</td> <td>C5210 t=0.25</td> <td>gold flash over nickel</td> </tr> <tr> <td>terminal 10</td> <td>C2680 t=0.25</td> <td>gold flash over nickel</td> </tr> <tr> <td>housing</td> <td>PA10T (UL94V-0)</td> <td>black</td> </tr> </tbody> </table>	DESCRIPTION	MATERIAL	PLATING/COLOR	terminal 1	C5210 t=0.25	gold flash over nickel	terminal 2	C5210 t=0.25	gold flash over nickel	terminal 3	C5210 t=0.25	gold flash over nickel	terminal 10	C2680 t=0.25	gold flash over nickel	housing	PA10T (UL94V-0)	black
	MATERIAL	PLATING																																			
terminal 1	copper alloy	silver																																			
terminal 2	copper alloy	silver																																			
terminal 3	copper alloy	silver																																			
terminal 10	copper alloy	silver																																			
plastic	PA10T																																				
DESCRIPTION	MATERIAL	PLATING/COLOR																																			
terminal 1	C5210 t=0.25	gold flash over nickel																																			
terminal 2	C5210 t=0.25	gold flash over nickel																																			
terminal 3	C5210 t=0.25	gold flash over nickel																																			
terminal 10	C2680 t=0.25	gold flash over nickel																																			
housing	PA10T (UL94V-0)	black																																			

F-723-001

Revision: A

SOLDERABILITY				
parameter	conditions/description	min	typ	max units
reel storage	at relative humidity <math>\leq 80\%</math>		40	$^{\circ}\text{C}$
reflow soldering <sup>1</sup>	see reflow profile	255	260	$^{\circ}\text{C}$

drying conditions<sup>2</sup> parts in reel: bake at 40°C ±5°C for 72 hours  
parts removed from reel: bake at 40°C ±5°C for 10 hours

Note: 1. Must reflow solder within 12 hours from opening vacuum packaging at a temperature <math>\leq 25^{\circ}\text{C}</math> in relative humidity <math>\leq 80\%</math>. 2. When unloading floor kits by <math>\geq 72</math> hours.

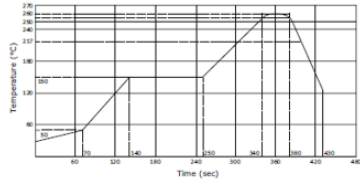

SOLDERABILITY				
parameter	conditions/description	min	typ	max units
reel storage	5-25°C, 20-75% humidity			
reflow soldering	see reflow profile	255	260	$^{\circ}\text{C}$

Note: 1. CU Devices recommends usage of the product within 24 hours after 100 is opened. After 24 hours, CU Devices recommends drying the parts prior to use.

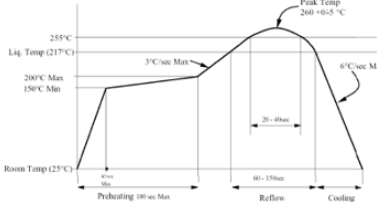
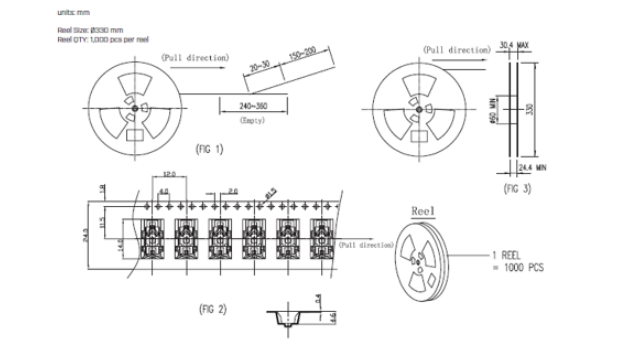
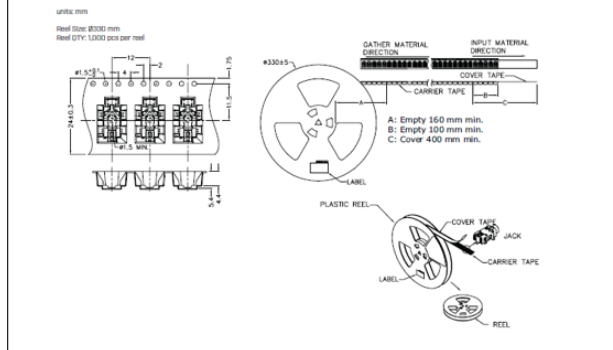
Affected Date Code: 6/15/2023

Product Availability: Channel Availability Q3

Additional Information:

PCN Approval:

Operations/Quality



Product Management

